

Advanced Computer Networks

Interconnection Layer 2: bridges and VLANs

Prof. Andrzej Duda
duda@imag.fr

http://duda.imag.fr

1

Contents

- Transparent bridges
- Spanning Tree Protocol (STP)
- Rapid Spanning Tree Protocol (RSTP)
- VLANs

2

Transparent Bridging (TB)

- Bridges are intermediate systems that forward MAC frames to destinations based on MAC addresses
- Interconnect systems beyond one LAN segment, keeping main characteristics of LAN
 - without additional addresses
 - MAC addresses used to identify end systems
- End systems ignore that there are transparent bridges
 - bridge is transparent
 - MAC frames not changed by bridges
 - frames not sent to bridge, but rather: bridge is promiscuous
 - listens to all frames and retransmits if needed

3

Transparent Bridging (TB)

- Administrator creates the forwarding table
- TB operation
 - connectionless forwarding, unstructured addresses

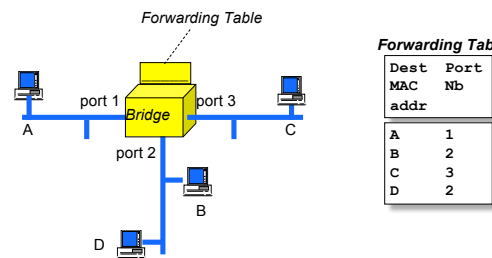

Dest MAC addr	Port Nb
A	1
B	2
C	3
D	2

4

LB: Learning Bridge

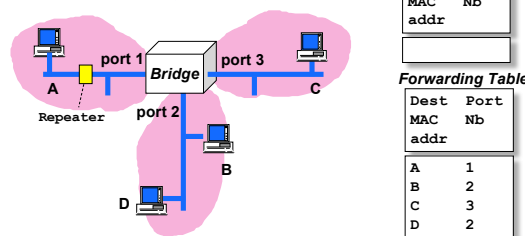

Dest MAC addr	Port Nb

Dest MAC addr	Port Nb
A	1
B	2
C	3
D	2

- Bridge builds forwarding table by reading all traffic
 - bridges are plug and play: no address configuration (no IP address needed)
 - table built by **learning** from SA field in MAC frame
 - a table entry has limited life (**MaxLife**, 5 minutes)
- Flooding if destination address unknown or group address

5

Several Learning Bridges

- Can the learning bridge be extended to a network of bridges?
- How does B2 see the network?

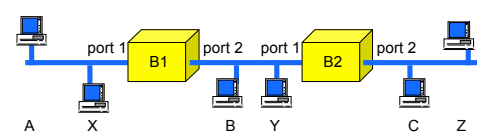

6

Loops

- What happens when A sends a frame to B?
 - assume empty forwarding table

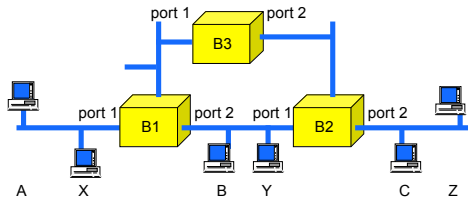

7

Loop-Free topology

- Learning bridge works well on Loop-Free topology only
 - Bidirectional graph: node = bridge, edge = connection through LAN
 - Loop free - bidirectional graph = bidirectional tree
 - examples: line, star
 - On a tree, there is only one path from A to B
 - Proposition:** If bridge topology is loop-free, then there exists only one path from any end system to any bridge
 - Loop-free topology is required and sufficient for

8

Spanning Tree Bridges

- Based on learning bridge:
 - table driven forwarding, flooding if unknown DA or multicast, learning
- Forces topology to a tree
 - Spanning Tree algorithm run by all bridges
 - Some ports blocked to prevent loops
 - ports that are allowed to forward frames (in either way) are said to be "in the forwarding state" or called "forwarding ports"
- Interconnection of bridges
 - several parallel paths for reliability
 - Spanning Tree algorithm chooses one path at a given instant

9

Forwarding Method

Individual PDU forwarding	<pre>Copy all frames on all forwarding ports Frame received on port i -> /* port i is forwarding */ If DA is unicast, is in forwarding table with port j and j is a forwarding port then copy to port j else flood all forwarding ports ≠ i Update forwarding table with (i, SA)</pre>
Control method	<pre>Maintain spanning tree and port states Learn addresses on reading traffic</pre>

10

TB Spanning Tree Specification

Set of bridges with
 - bridge Id and prio
 - bridge ports on LANs
 - LAN costs

⇒ **TB Spanning Tree** ⇒

One bridge selected as root
 On every bridge
 - one root port
 - designated ports
 (other ports are blocked)

- Bridges viewed as a bidirectional graph (nodes = bridges)
- Selection of the root bridge
 - lowest priority with lowest identifier
- Spanning Tree = shortest path tree from root to all bridges
 - edge costs set by management, high cost = less traffic
 - based on distributed Bellman-Ford (distance vector)
 - $cost_to_root = best_announced_cost + local_cost$

11

Spanning Tree Specification

- Root** port on one bridge = port towards root, shortest path
 - in case of equal costs, lowest id chosen
- Designated bridge
 - one per LAN
 - it has the shortest path to root via root port
- Designated** ports
 - all ports for which the bridge is designated
 - connect LANs to the spanning tree
- Ports other than root or designated are **blocked**
- Configuration messages
 - $rootId.cost_to_root.senderId.port$ (41.13.92.3)
 - simplified: $rootId.cost_to_root.senderId$

12

Spanning Tree example

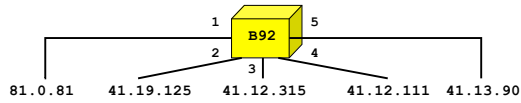

- Best root: 41
- Best cost: $12 + 1 = 13$, on port 3 or 4 (cost=1)
- **Root port:** 4, because $111 < 315$
- New message: 41.13.92
- Ports 1 and 2 are **designated**: 41.13.92 is better than 81.0.0.81 and 41.19.125
- Port 3 and 5 are **blocked**: 41.13.92 is not better than 41.12.315 nor 41.13.90

13

Spanning Tree example

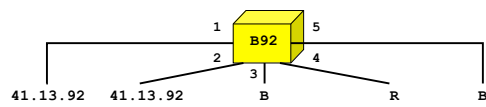

- Message 41.13.92 sent periodically on ports 1 and 2
- Ports 1, 2, 4 participate in forwarding (they are in the Spanning Tree)

14

Spanning Tree example

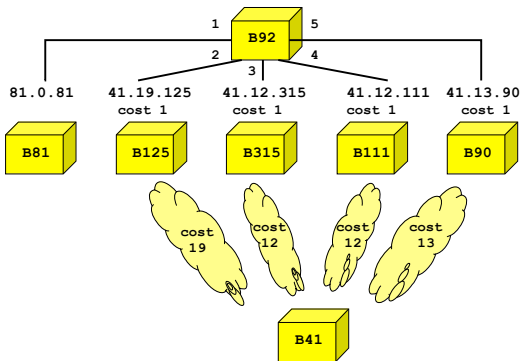

15

Spanning Tree example

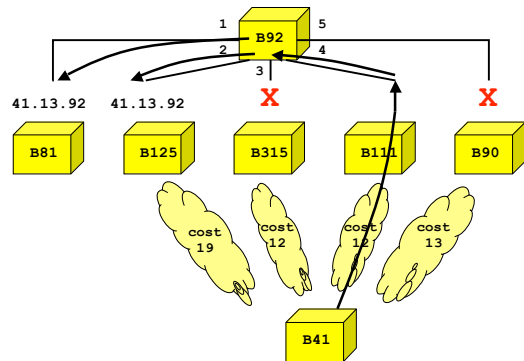

16

STP - Spanning Tree protocol

- IEEE 802.1D
- Distributed in all bridges
- Bridges exchange messages with neighbours in order to both
 - elect a root
 - determine shortest path tree to root
 - root port = port towards root on shortest path tree
 - designated ports = connect LANs to the spanning tree
 - designated bridge = one per LAN, has shortest path to root via root port

17

STP (IEEE 802.1d)

- Each bridge has a Bridge Identifier number, based on MAC address + configurable offset
- Bridge with smallest Bridge Identifier is the "root"
- Each link has a cost

Link Bit Rate	Cost
4 Mb/s	250
10 Mb/s	100
16 Mb/s	62
45 Mb/s	39
100 Mb/s	19
155 Mb/s	14
622 Mb/s	6
1 Gb/s	4
10 Gb/s	2

18

Bridge PDUs

- Control method uses control frames called Bridge PDUs (BPDUs)
 - 802.3 encapsulation, LLC frame with SAP = x42
 - MAC DA = all bridges (multicast) 01 80 C2 00 00 00
- BPDUs are not forwarded by bridges
 - unlike all other frames BPDUs are sent by one bridge to all bridges on the same LAN segment
 - reminder: a data frame is never sent to bridge by end system
- Configuration BPDU contains
 - root Id
 - cost to root (from sender of config BPDU)
 - id of sender
 - port number (omitted in the examples)

19

Initialization of Spanning Tree

- Bridge initially assumes self as a root
- Bridge computes own new config BPDU based on received information
 - determine best root so far
 - distance to root with Bellman-Ford

$$\text{distance } D \text{ from me to root} = \min [D(\text{me}, \text{neighbor}) + D(\text{neighbor}, \text{root})]$$
- On every port, Bridge transmits config BPDU until it receives a better config BPDU on that port
 - better = closer to root (lower cost or lower Id)
- On every port, bridge maintains copy of best config BPDU sent or received

20

Basic ST Procedure

```

config BPDU received on any port or port enabled ->

compute new root;
compute new cost to root; /* Bellman Ford */
build new_config_BPDU;
for all ports i do
    if new_config_BPDU better than stored_config[i]
        then store and send on port i;
end

compute root port /* smaller distance to root */
designated ports = ports where config BPDU was sent
blocked ports = other ports

r.c.s better than r'.c'.s' iff
(r < r') or (r = r' and c < c') or (r = r' and c = c' and s < s')
    
```

22

Complex example

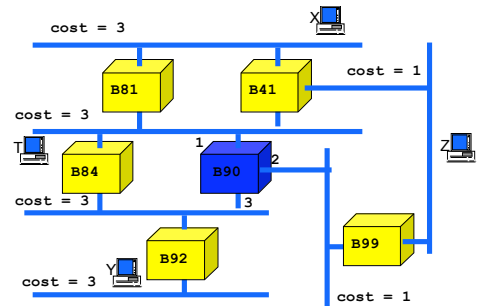

Initialization of Spanning Tree

- Bridge B90 prepares config BPDU 90.0.0.90 and sends on all ports; B90 configuration tables:

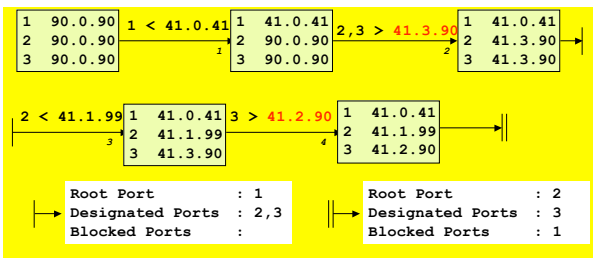

message received on port 1: 1 < 41.0.41 message format: rootId.cost_to_root.senderId

Comments

- When receiving a message we compare the cost (with the local cost included), but we store the message received (without the cost)
- On receiving 41.0.41 on port 1:
 - 41.3.41 < 90.0.90? yes -> 1 becomes root
 - new config msg = 41.3.90
 - 41.3.90 < 90.0.90? yes -> 2 becomes designated
 - 41.3.90 < 90.0.90? yes -> 3 becomes designated
- On receiving 41.1.99 on port 2:
 - 41.2.99 < 41.3.41? yes -> 2 becomes root
 - new config msg = 41.2.90
 - 41.2.90 < 41.3.90? yes -> 3 becomes designated
 - 41.2.90 < 41.0.41? no -> 1 becomes blocked

24

Constructed ST

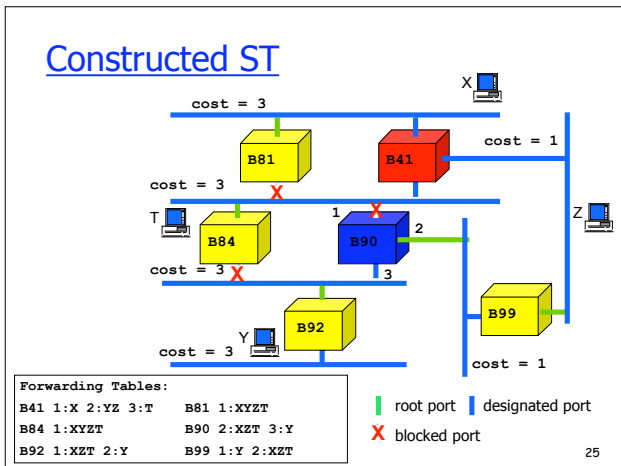

STP Topology Management

- Topology change can be
 - local** - a configuration msg changes the state of a port (one port changes into the Forwarding or Blocking state)
 - global** - topology update mechanism via root
- Detection
 - configuration message is too old (the path to the root is no longer available)
 - receive a new better configuration
- When topology change detected
 - inform root
 - restart spanning tree computation
 - force bridges to use a shorter timeout interval (purge the forwarding table)

26

Topology change

- When one bridge detects a topology change
 - bridge sends topology update BPDU towards root and enters Listening state (upstream bridges repeat BPDU up to root)
 - root forwards new config BPDU with "topology change flag" set during **ForwardDelay** (15 s) + **MaxAge** (20 s)
 - causes all bridges to use the short timeout value for the forwarding table (see later)
 - until BPDU from root received with "topology change" flag cleared

27

Example

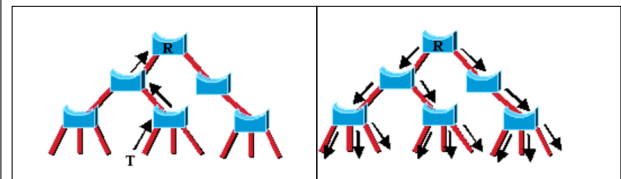

New link added to bridge
Topology update sent to root

Topology update sent by root on ST for
MaxAge + ForwardDelay
All bridges recompute ST + set forwarding tables in learning state

Source: CISCO RSTP White Paper

28

Configuration monitoring

- root sends a configuration message every **HelloTime** (2 s)
- message received with **Age**, retransmitted with **Age** += 1
- if **Age** = **MaxAge** (20 s), delete the stored configuration and restarts basic ST procedure

```

Root sends config BPDUs every HelloTime;

Bridge B receives config BPDU on root port i ->
Reset timer Age on stored_config[i]
for all designated ports j
    B sends own config BPDU
    B resets timer Age on stored_config[j]

Bridge B timeouts (MaxAge) stored_config[j]->
delete stored_config[j];
B performs basic ST procedure;
    
```

29

Timers

- Timers used in topology management
 - HelloTime** (2 s): time interval between Config BPDUs sent by the Root Bridge.
 - ForwardDelay** (15 s): time interval that a bridge port spends in both the Listening and Learning states
 - MaxAge** (20 s): time interval that a bridge stores a BPDU before discarding it
 - recommended values for a spanning tree of diameter 7
- Time to update
 - detect and rebuild: 35 s = 20 s + 15 s
- Time to change from blocking to forwarding state
 - detect, rebuild, and learn addresses: 50 s = 20 s + 15 s + 15 s

30

Constructed ST

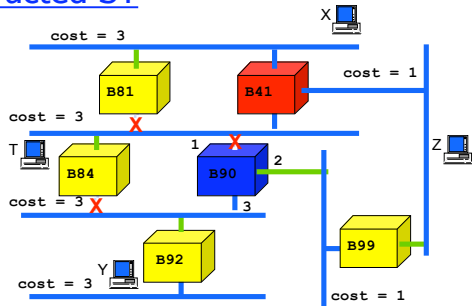

Forwarding Tables:

B41 1:X 2:YZ 3:T B81 1:XYZT
 B84 1:XYZT B90 2:XZT 3:Y
 B92 1:XZT 2:Y B99 1:Y 2:XZT

■ root port ■ designated port
 X blocked port

31

Example

- B99 powered off; stored config at B90:

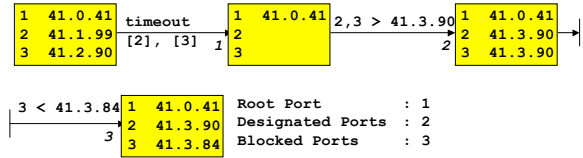

- Spanning Tree after failure?

32

Comments

- After timeout:
 - 41.3.41 is the best configuration -> 1 becomes root
 - new config msg = 41.3.90
 - 2 and 3 becomes designated
- On receiving 41.3.84 on port 3:
 - 41.6.84 < 41.3.41? no -> 1 stays root
 - new config msg = 41.3.90
 - 2 stays designated
 - 41.3.90 < 41.3.84? no -> 3 becomes blocked

33

ST after failure

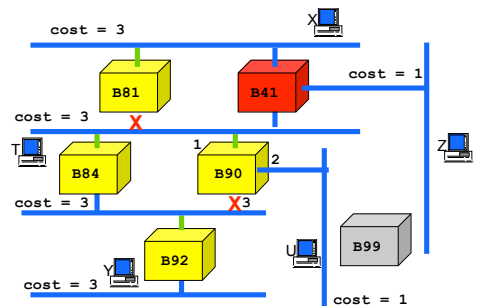

34

Synchronization with Forwarding

- Topology changes cause loops or loss of connectivity
 - during reconfiguration, topology is not yet (in general) loop free
 - even transient loops should be avoided
- Solution: Forwarding state is not immediately operational
 - pre-forwarding states:
 - Listening (accept config msgs, no forwarding): wait for stabilization of ST (ForwardDelay, 15 sec)
 - Learning (learn MAC addresses, no forwarding): wait for addresses to be learnt (ForwardDelay, 15 sec)

State	Actions		
	Forward	ST	Learn
Blocking		X	
Listening		X	
Learning		X	X
Forwarding	X	X	X

35

Forwarding Table entry timers

- MaxLife** = duration of an entry in the forwarding table
- Two timer values are used
 - long timer (5mn): normal case
 - short timer = **ForwardDelay** (15 s): after spanning tree updates
- Timer switching mechanism
 - Bridge B detects change in ST -> **MaxLife** = **ForwardDelay**

36

Example

- Bridge A newly connected to root. What happens ?

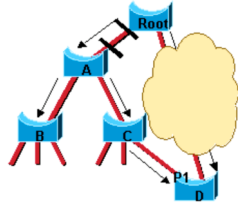

Source: CISCO RSTP White Paper

37

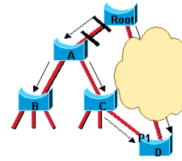

1. A and root run ST procedure on new ports.
2. This triggers new BPDUs sent to B and C
3. D computes port p1 as new root

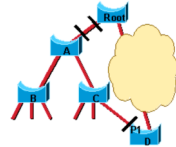

1. p1 at D is set to listening state for 15 s
2. p1 at D is set to learning state for 15 s

⇒ topology change is fast (in this case), but forwarding is not enabled immediately

38

Efficiency?

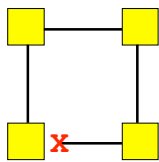

- No loops, but paths may be not optimal
 - All frames go through the spanning tree

39

RSTP - Rapid ST protocol

- IEEE 802.1W
- Evolution of STP
- Goal: fast reconfiguration
- Improvement of handling topology changes and synchronization with packet forwarding
 - avoids use of timers as much as possible
- Main improvements are
 - fast reconfiguration: use of alternate paths to root or backup path to a LAN
 - fast transition to forwarding state with negotiation protocol instead of relying on timers
 - fast flushing of forwarding tables after topology changes

40

Port Roles in RSTP

- A port **role** is one of: root, designated, alternate, backup, blocked
- root** port = port towards root (same as STP)
- designated** port = connects LAN to the spanning tree (same as STP)
- Port that is not root nor designated
 - is **alternate**: connects the bridge to root after topology update (alternate path to root)
 - is **backup**: connects LAN to the spanning tree after topology update (alternate path to root for the LAN)
 - is **blocked**: not in the spanning tree

41

Another example of STP

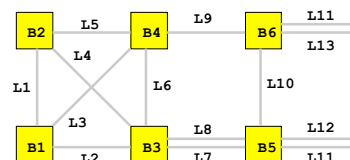

42

Constructed ST

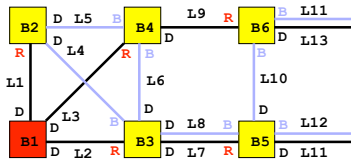

- B1 - root
- R - root ports, D - designated ports, B - blocked ports

43

ST constructed by RSTP

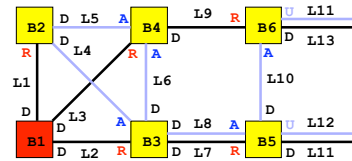

- B1 - root
- R - root ports, D - designated ports, B - blocked ports
- A - alternative ports, U - backup ports

44

L3 fails

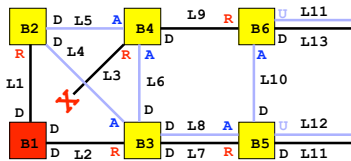

- B1 - root
- R - root ports, D - designated ports, B - blocked ports
- A - alternative ports, U - backup ports

45

L3 fails

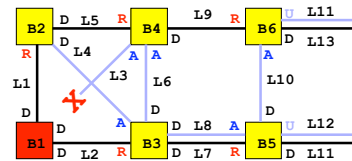

- On B4
 - port on L3 becomes A and state Destruction
 - port on L5 becomes R and state Forwarding

46

L11 fails

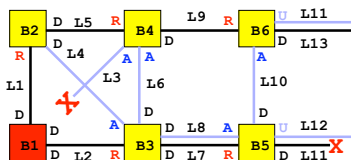

- B1 - root
- R - root ports, D - designated ports, B - blocked ports
- A - alternative ports, U - backup ports

47

L11 fails

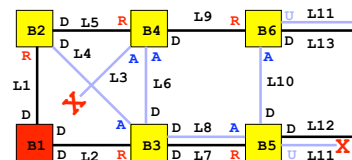

- On B5
 - port on L11 becomes U and state Destruction
 - port on L12 becomes D and state Forwarding

48

RSTP - Rapid ST protocol

- If topology change
 - same reconstruction protocol as STP
 - topology change notification flooded across ST
- Rapid recovery
 - Proposal/Agreement sequence between bridges that change state of a port: immediate transition to Forwarding state
 - link failure detection by MAC layer
 - change R to A and D to U (order of 10 ms)
 - but similar delay to STP, if topology update

49

VLAN - Virtual LAN

- Keep the advantages of Layer 2 interconnection
 - auto-configuration (addresses, topology - Spanning Tree)
 - performance of switching
- Enhance with functionalities of Layer 3
 - extensibility
 - spanning large distances
 - traffic filtering
- Limit broadcast domains
- Security
 - separate subnetworks

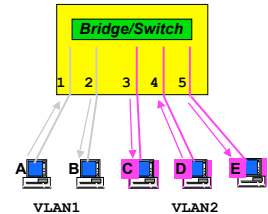

50

Virtual LANs

- No traffic between different VLANs
- VLANs build on bridges or switches

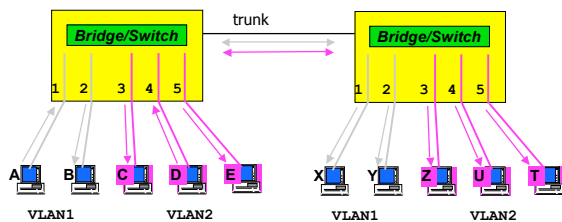

51

VLANs

- How to define which port belongs to a VLAN?
 - per port
 - simple, secure, not flexible for moving hosts (one host per port)
 - per MAC address
 - several hosts per port, flexible for moving hosts, not secure, difficult to manage, problems with protocols Layer 3 (should be coupled with dynamic address negotiation - DHCP)
 - per Layer 3 protocol
 - allows to limit frame broadcast (VLAN1: IP, VLAN2: IPX)
 - per Layer 3 address
 - one VLAN per IP subnetwork
 - flexible for moving hosts
 - less efficient (requires inspecting packets)
 - per IP Multicast group
 - hosts that join an IP multicast group can be seen as members of the same virtual LAN

52

VLANs

- How to extend VLAN to several bridges/switches?
 - needs frame identification - *tagging*
- Frame tagging
 - explicit tagging
 - add VLAN identifier to MAC frames
 - implicit tagging
 - VLAN Id deduced from port number, MAC address, layer 3 protocol, layer 3 address, IP Multicast group
 - implicit tagging makes use of filtering database
 - mapping between VLAN Id and the appropriate field (e.g. layer 3 address)

53

Frame tagging

- VLAN identifier in frames
 - usually done by the first switch/bridge
 - host is not aware of tagging
- Standards
 - CISCO: ISL (Inter-Switch Link)
 - IEEE 802.1Q/802.1P

54

ISL (Inter-Switch Link)

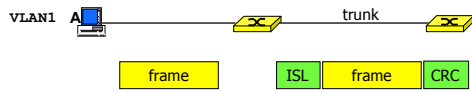

- CISCO: ISL (Inter-Switch Link)
 - proprietary solution: encapsulates a frame in an ISL frame (26 bytes header, 4 bytes CRC)
 - incompatible with other vendors - accepts increased maximal length of 802.3 frame

55

802.1Q

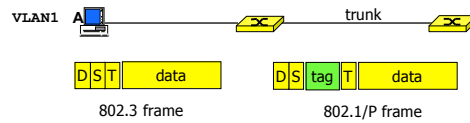

- Frame encapsulation of IEEE 802.1P
 - extension for assigning frame priority and VLAN tag
 - 2 bytes of TPI (Tag Protocol Information): x8100
 - 2 bytes of TCI (Tag Control Information): priority (3 bits), VLAN Id (12 bits)
 - length may exceed 1500 bytes (a standard project extends the maximal size of the data to 1512 bytes)

56

802.1Q

- Bridge/switch keeps track of VLAN members based on dynamic filtering entries
 - Dynamic Registration: specify ports registered for a specific VLAN
 - added and deleted using GARP VLAN Registration Protocol (GVRP), GARP is the Generic Attribute Registration Protocol
 - Group Registration: indicate frames to a group MAC address
 - added and deleted using Group Multicast Registration Protocol (GMRP)
 - multicasts sent on a single VLAN without affecting other VLANs

57

GARP

- Defines
 - method to declare attributes to other GARP participants
 - frame type to use (GPDU)
 - rules for registering/deleting attributes
- How does it work?
 - bridge wants to declare an attribute
 - send a declaration
 - other bridges propagate the declaration

58

GARP

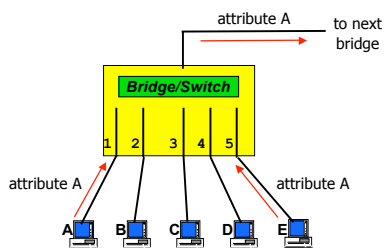

- Attribute propagation
 - stored at bridge
 - multiple attributes are filtered out - only one declaration is propagated
 - propagation follows the spanning tree of bridges

59

GARP

- Attributes on VLAN membership are sent over the tree
- Frames are forwarded according to this information

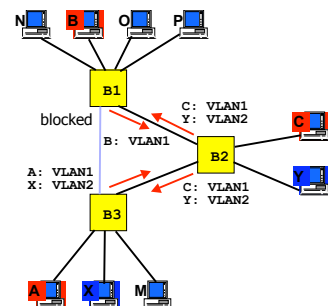

60

Remote VLANs

- Interconnect remote switches/bridges
- Uses ATM or other proprietary methods as a physical layer

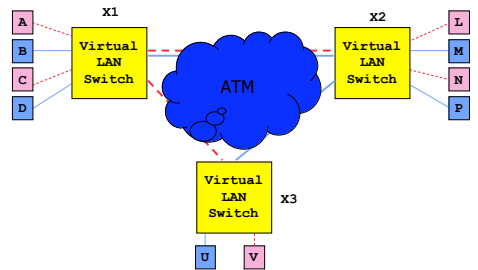

61

GMRP

IP: 224.2.166.207
Ether: 01-00-5E-02-A6-CF

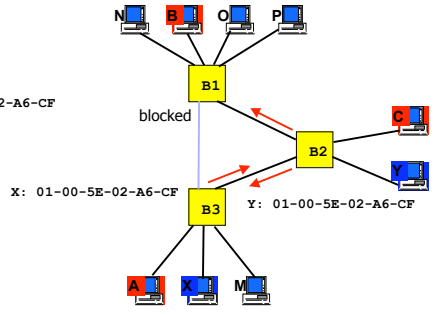

- Register to a group address - it uses GARP
- Multicast frames are forwarded according to this information

62

Conclusion

- Ethernet switches/bridges dominate
- 100 Mb/s switches for hosts, 1 Gb/s in the backbone
- Complex interconnection
 - parallel paths may exist for reliability
 - SPT or RSTP guarantees loop-free interconnection
 - VLANs help to structure the interconnection
 - separate broadcast domains
 - limited scalability
- Products
 - Switch/Router - integrated ports: Layer 2 and Layer 3
 - administrator chooses the right level for each port

63